

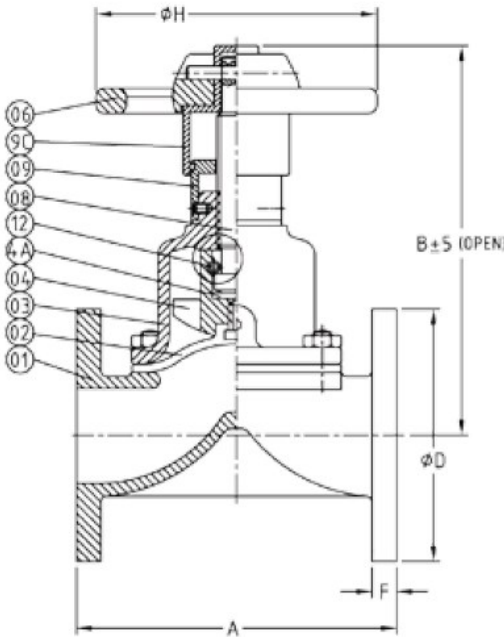

Diaphragm Valve Weir Type

Features

- Flange PN10/16 (520) or ASA150 (530)
- Cast Iron Body Unlined
- Rising Handwheel Indicator Bonnet



Diaphragm Available	Temperature Range
Grade A - Natural Rubber	-30°C to +80°C
Grade EP - EPDM	-30°C to +150°C
Grade R - Nitrile	-10°C to +90°C
Grade N - Neoprene	-25°C to +95°C
Grade B - Butyl	-25°C to +120°C
Grade H - Hypalon	-15°C to +100°C
Grade V - Viton	-5°C to +150°C
Grade T - PTFE/Neoprene	-30°C to +120°C

Technical Data		
15mm to 50mm	65mm to 150mm	200mm
16 bar	10 bar	7 bar

N.	Part Name	Materials
1	Body	Cast Iron
2	Diaphragm	As per list
3	Bonnet	Cast Iron
4	Compressor	Cast Iron
4A	Thrust Pad	Delrin/PTFE
6	Handwheel	Cast Iron
8	Stem	Stainless Steel 410
9	Indicator	Cast Iron
9C	Indicator Cap	Cast Iron
12	Spring Dowel Sleeve	Spring Steel

DN	15	20	25	32	40	50	65	80	100	125	150	200
A	108	117	127	146	159	190	216	254	305	356	406	521
B (open)	105	115	132	140	180	210	235	305	340	420	490	645
øD	95	105	115	140	150	165	185	200	229	254	285	343
F	12	12	12	15	15	17.5	18	19	23.8	23.8	25.4	22
øH	80	80	100	100	100	180	180	225	225	310	358	471
Kgs	2.6	2.8	3.5	4.8	6.5	10.5	15	22	36	61	89	165

Dimensions in mm

This data sheet is designed as a guide and should not be regarded as wholly accurate in every detail. We reserve the right to amend the specification of any product without notice.