

V-FLOW

SOLUTIONS LTD

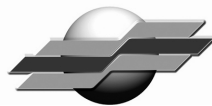

COMPARATO®

**COMPACT PRO, COMPACT DC PRO
& UNIVERSAL PRO**

OPERATING & INSTALLATION MANUAL

Compact PRO, Compact DC PRO & Universal PRO



Technical Features:

Electric motor – Bidirectional

Power supply: 230v, 110v or 24v 50Hz (50/60Hz available on Compact PRO)
12v, 24v AC/DC 50/60 Hz (DC PRO)

Operating speed: 230v, 110v or 24vAC 55s (32s, 14s on request Universal PRO)
230v, 110v or 24vAC 45s (9s on request Compact PRO)
12v, 24v AC/DC 10s (30s on request Compact DC PRO)

Maximum power consumption: Universal PRO 55s (230v, 110v and 24v versions have 9.2VA consumption)
14s-32s (230v, 110v and 24v versions have 16VA consumption)
Compact PRO 45s (230v, 110v versions have 5VA consumption, 24v has 5.5VA)
9s (230v, 110v and 24v versions have 16VA consumption)
Compact DC PRO 10s, 30s (12v AC/DC 1.5A) (24v AC/DC 1.0A)

Degree of protection: IP67 for all Universal and Compact PRO models.

Maximum power output of auxiliary micro switches: 1A, resistive

Ambient temperature range: -10°C max. 50°C

Incorrect installation of the Universal or Compact actuator can put the unit at risk of damage, please follow these instructions.

Electrical connections:

Electrical connections must be carried out by a qualified electrician.

Before making any electrical connections it is essential that the power supply is isolated. To access the terminal strip and printed circuit board it is necessary to remove the cover of the actuator by undoing the four screws. Remove the cable gland plug and screw in the cable gland. Wire actuator as indicated on the wiring diagram supplied. Ensure that the cable is correctly installed and the gland is suitably tightened, please also ensure that the actuator cover is refitted correctly and the seal is not pinched before tightening.

Electrical Features:

When installing the Universal or Compact actuator it is important to ensure that the correct model is being used, taking into account the environment and ambient temperatures. If the unit is to be installed outdoors or in a cold and damp environment we recommend that the optional anti-condensation heater is fitted. If you are unsure please contact the technical department for advice.

Please ensure that all equipment is suitably earthed and the correct thermo-magnetic switches/fuses and circuit breakers are used in order to guarantee safe operation and to comply with safety regulations.



Compact PRO, Compact DC PRO & Universal PRO



Manual override

The Universal PRO and Compact PRO is fitted with a manual override facility as standard on AC models only. DC models are not available with the manual override.



MANUAL OVERRIDE

In the event of mains failure the valve will remain in its current position
In case of emergency the valve can be operated manually by holding down the declutch button 'a' whilst turning the T-Bar 'b' to the desired position



IMPORTANT

Only operate manually when the unit is:
'Electrically Isolated' or in the 'Event of Power Failure'

Caution

Manual operation of the actuator is only permitted when the unit is isolated from the power supply.

If a blockage in the valve is encountered, proceed as follows:

- Isolate power supply
- Push the declutch button and open the valve manually
- Try to free the blockage.

If its not possible to free the blockage it may be necessary to remove the valve from the line for further inspection.

Important: Do not exert too much force on manual override T bar to avoid damaging the valve or actuator.

(Optional) Anti-condensation heater AC models only

If the environment that the Universal or Compact actuator is installed is likely to be cold or wet we would recommend installing an anti-condensation heater. The heater will reduce the risk of condensation and subsequent corrosion of internal

components. This is an option that can be ordered with the actuator or retrofitted. Please contact the technical department for further details.

The Anti-condensation heater is to be screwed to the base of the actuator and will partially wrap around the motor. It is not necessary to wire the heater through the terminal strip, instead direct wiring using standard fasten connectors is possible. The heater is not phase dependent therefore live and neutral can be connected to either wire. It is essential to use the correct voltage heater, which is indicated on the labelling.



Universal PRO

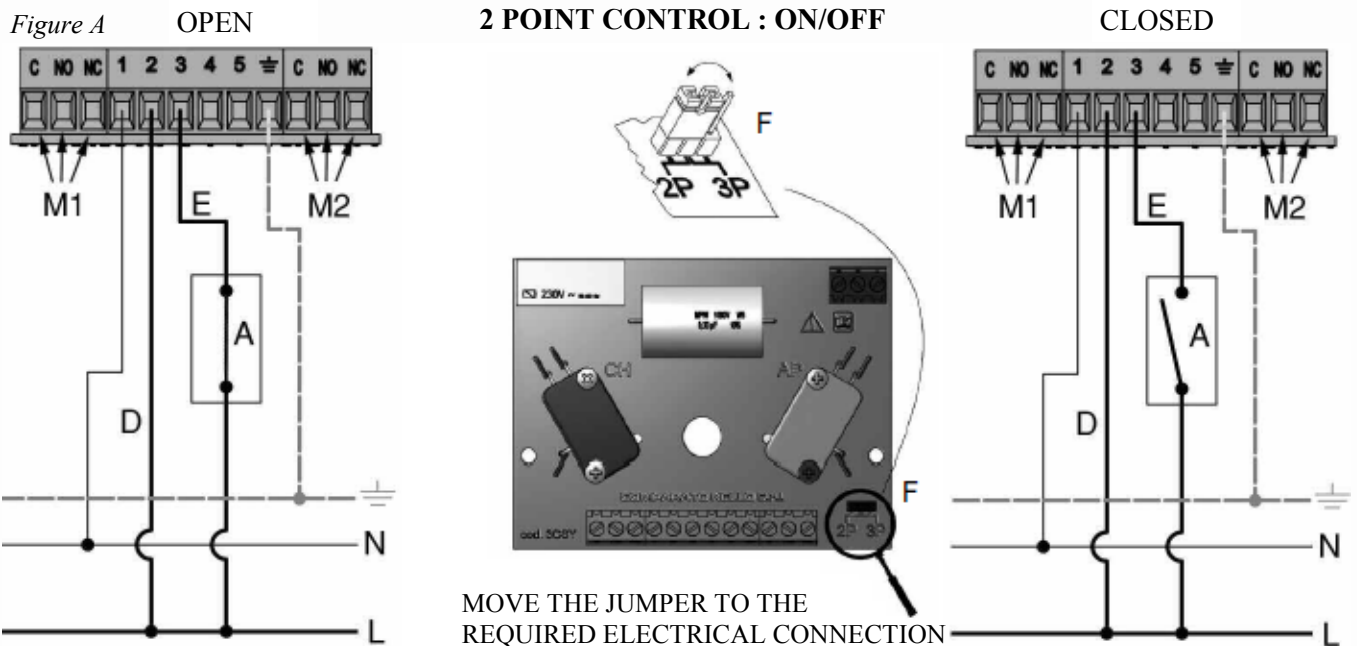

- 1: NEUTRAL
- 2: PERMANENT LIVE — CLOSE
- 3: SWITCHED LIVE — OPEN
- 4: LIVE OUTPUT — OPEN
- 5: LIVE OUTPUT — CLOSE

- C: COMMON
- NO: NORMALLY OPEN
- NC: NORMALLY CLOSED
- M1: AUXILIARY MICRO SWITCH
- M2: AUXILIARY MICRO

- A: SWITCH
- D: CLOSE
- E: OPEN/ CLOSE
- F: JUMPER

TERMINAL NO. 3: WHEN SWITCH ' A ' IS IN THE CLOSED POSITION THE ACTUATOR OPENS
 WHEN SWITCH ' A ' IS IN THE OPEN POSITION THE ACTUATOR CLOSES

Electrical Connections

All Universal PRO actuators are equipped with an “All in One” system which allows the installer to set the actuator for either 2 point or 3 point electrical control according to the specific requirements. To make this selection a jumper can be changed between 2P (2 point) or 3P (3 point).

Figure A shows the 2 point connections. The permanent live must be connected to terminal 2; the switched live is to be connected to terminal 3 which opens the actuator. By removing the live on the terminal 3 the actuated closes..

In both cases (for 2 point and 3 point) connect the neutral to terminal 1.

With the 2 point connection it is possible to operate multiple actuators from the same control device (e.g. thermostat, relay, switch etc.). With the 3 point connection it is possible to operate only one actuator with its dedicated control device. It is also possible to position the actuator using the 3 point connection providing it is controlled by a suitable device.

Auxiliary Micro Switches

M1 (Opening auxiliary Micro Switch)

CLOSED VALVE

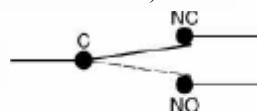

OPEN VALVE

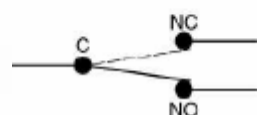

M2 (Closing auxiliary Micro Switch)

OPEN VALVE

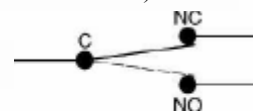

CLOSED VALVE

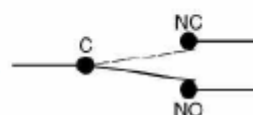

Universal PRO

3 POINT CONTROL : ON/OFF

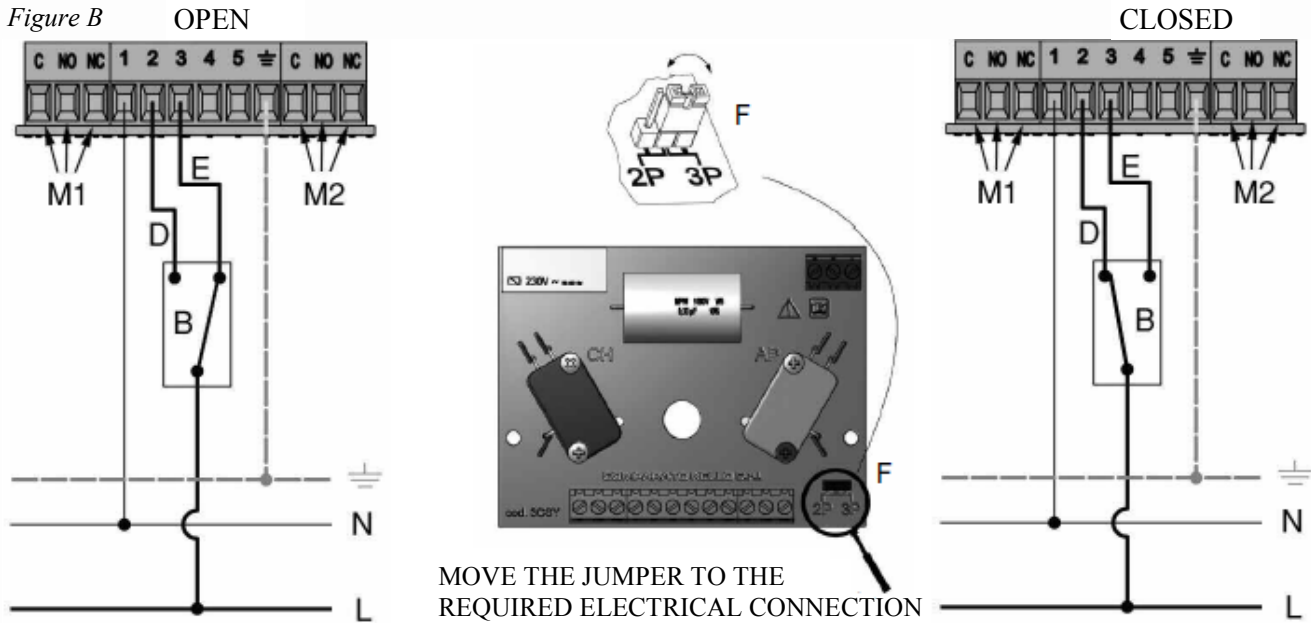

- 1: NEUTRAL
- 2: LIVE — CLOSE
- 3: LIVE — OPEN
- 4: LIVE OUTPUT — OPEN
- 5: LIVE OUTPUT — CLOSE

- C: COMMON
- NO: NORMALLY OPEN
- NC: NORMALLY CLOSED
- M1: AUXILIARY MICRO SWITCH
- M2: AUXILIARY MICRO

- B: SWITCH
- D: CLOSE
- E: OPEN
- F: JUMPER

Electrical Connections

All Universal PRO actuators are equipped with an “All in One” system which allows the installer to set the actuator for either 2 point or 3 point electrical control according to the specific requirements. To make this selection a jumper can be changed between 2P (2 point) or 3P (3 point).

Figure B shows the 3 point connections. In this case the live is switched between terminals 2 and 3. Live to both terminals 2 and 3 is not permitted.

In both cases (for 2 point and 3 point) connect the neutral to terminal 1.

With the 2 point connection it is possible to operate multiple actuators from the same control device (e.g. thermostat, relay, switch etc.). With the 3 point connection it is possible to operate only one actuator with its dedicated control device. It is also possible to position the actuator using the 3 point connection providing it is controlled by a suitable device.

Auxiliary Micro Switches

M1 (Opening auxiliary Micro Switch)

CLOSED VALVE

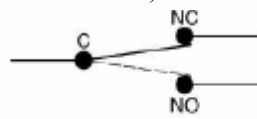

OPEN VALVE

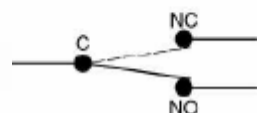

M2 (Closing auxiliary Micro Switch)

OPEN VALVE

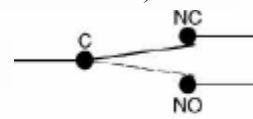

CLOSED VALVE

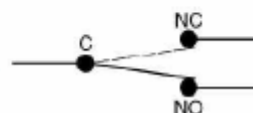

COMPACT PRO

2 POINT CONTROL : ON/OFF

Figure A OPEN

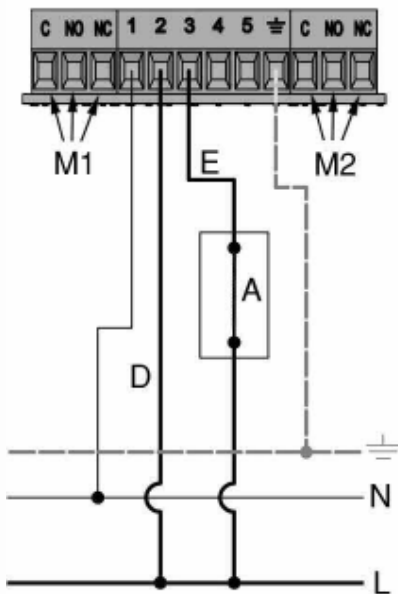

- 1: NEUTRAL
- 2: PERMANENT LIVE —CLOSE
- 3: SWITCHED LIVE —OPEN
- 4: LIVE OUTPUT —OPEN
- 5: LIVE OUTPUT —CLOSE

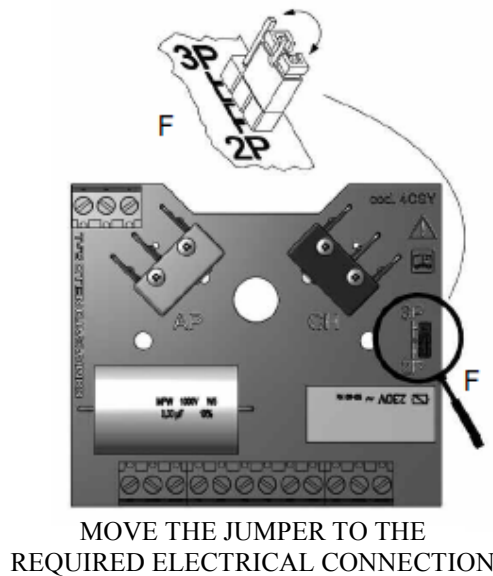

- C: COMMON
- NO: NORMALLY OPEN
- NC: NORMALLY CLOSED
- M1: AUXILIARY MICRO SWITCH
- M2: AUXILIARY MICRO SWITCH

CLOSE

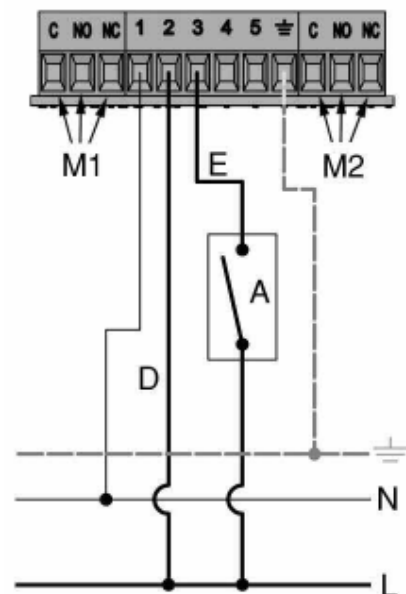

- A: SWITCH
- D: CLOSE
- E: OPEN/ CLOSE
- F: JUMPER

TERMINAL NO. 3: WHEN SWITCH ' A ' IS IN THE CLOSED POSITION THE ACTUATOR OPENS
WHEN SWITCH ' A ' IS IN THE OPEN POSITION THE ACTUATOR CLOSES

Electrical Connections

All Compact PRO actuators are equipped with an "All in One" system which allows the installer to set the actuator for either 2 point or 3 point electrical control according to the specific requirements. To make this selection a jumper can be changed between 2P (2 point) or 3P (3 point).

Figure A shows the 2 point connections. The permanent live must be connected to terminal 2; the switched live is to be connected to terminal 3 which opens the actuator. By removing the live on the terminal 3 the actuated closes. In both cases (for 2 point and 3 point) connect the neutral to terminal 1. With the 2 point connection it is possible to operate multiple actuators from the same control device (e.g. thermostat, relay, switch etc.). With the 3 point connection it is possible to operate only one actuator with its dedicated control device. It is also possible to position the actuator using the 3 point connection providing it is controlled by a suitable device.

Auxiliary Micro Switches

M1 (Opening auxiliary Micro Switch)

CLOSED VALVE

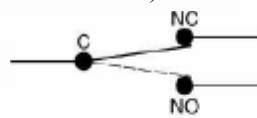

OPEN VALVE

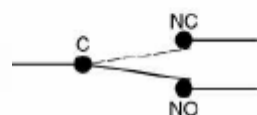

M2 (Closing auxiliary Micro Switch)

OPEN VALVE

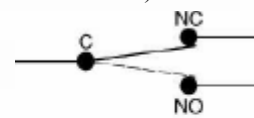

CLOSED VALVE

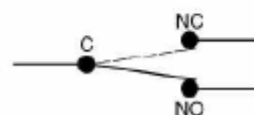

COMPACT PRO

3 POINT CONTROL : ON/OFF

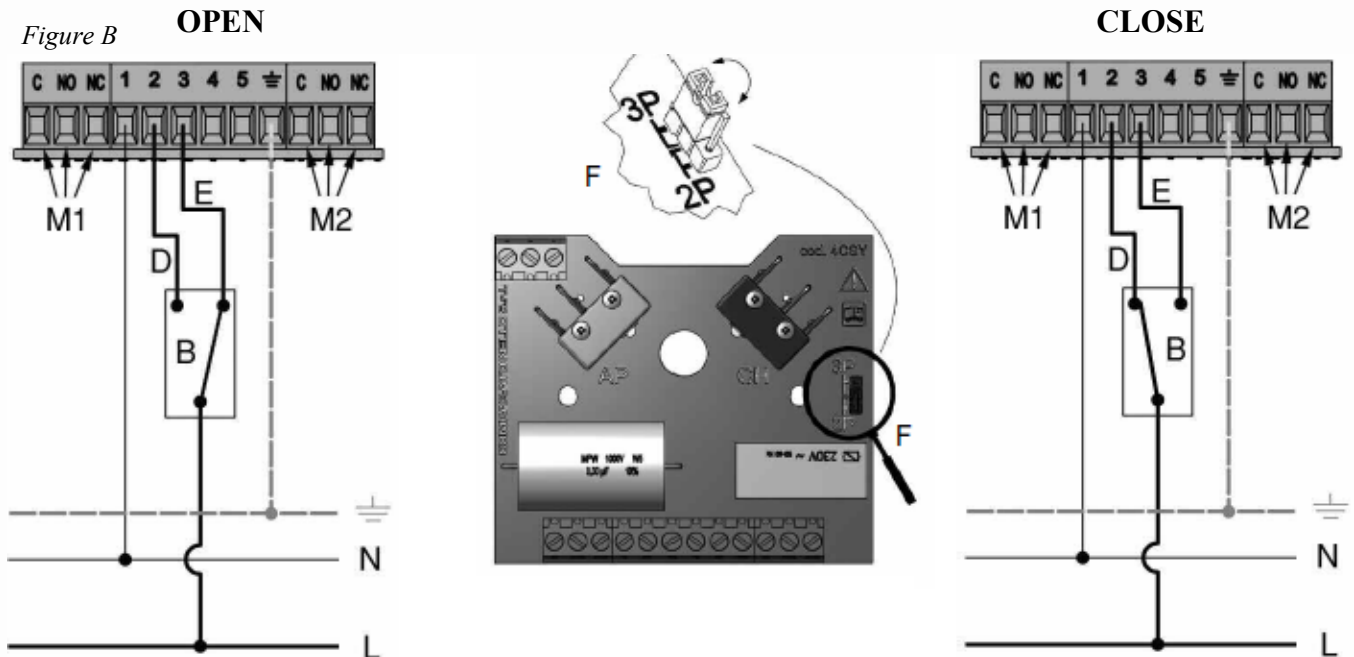

- 1: NEUTRAL
- 2: LIVE —CLOSE
- 3: LIVE —OPEN
- 4: LIVE OUTPUT —OPEN
- 5: LIVE OUTPUT —CLOSE

- C: COMMON
- NO: NORMALLY OPEN
- NC: NORMALLY CLOSED
- M1: AUXILIARY MICRO SWITCH
- M2: AUXILIARY MICRO SWITCH

- B: SWITCH
- D: CLOSE
- E: OPEN
- F: JUMPER

Electrical Connections

All Compact PRO actuators are equipped with an “All in One” system which allows the installer to set the actuator for either 2 point or 3 point electrical control according to the specific requirements. To make this selection a jumper can be changed between 2P (2 point) or 3P (3 point).

Figure B shows the 3 point connections. In this case the live is switched between terminals 2 and 3. Live to both terminals 2 and 3 is not permitted.

In both cases (for 2 point and 3 point) connect the neutral to terminal 1.

With the 2 point connection it is possible to operate multiple actuators from the same control device (e.g. thermostat, relay, switch etc.). With the 3 point connection it is possible to operate only one actuator with its dedicated control device. It is also possible to position the actuator using the 3 point connection providing it is controlled by a suitable device.

Auxiliary Micro Switches

M1 (Opening auxiliary Micro Switch)

CLOSED VALVE

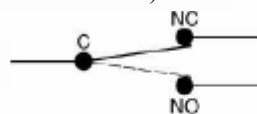

OPEN VALVE

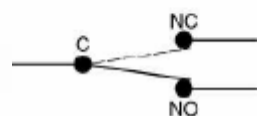

M2 (Closing auxiliary Micro Switch)

OPEN VALVE

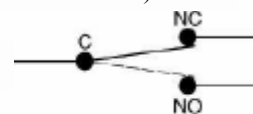

CLOSED VALVE

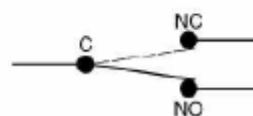

2 POINT CONTROL : ON/OFF

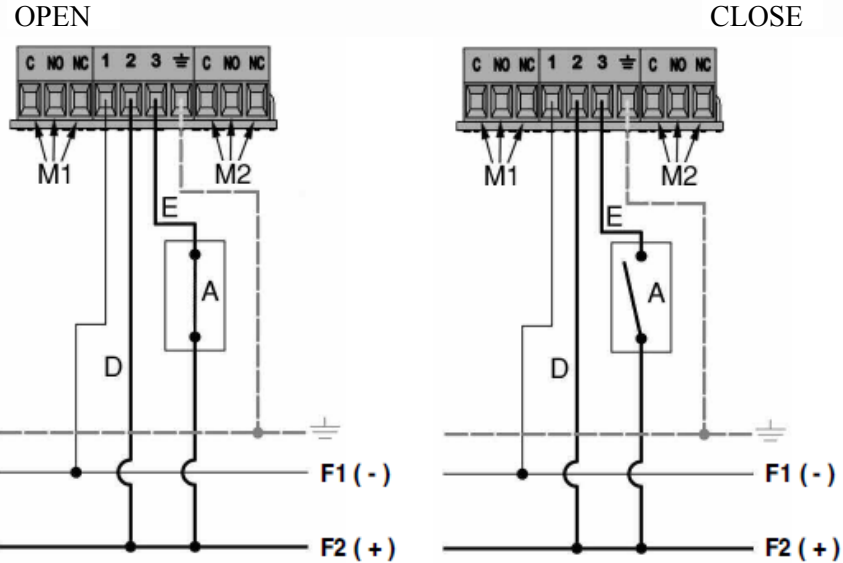

A: SWITCH
 D: CLOSE
 E:: OPEN

C: COMMON
 NO: NORMALLY OPEN
 NC: NORMALLY CLOSED
 M1: AUXILIARY MICRO

1: NEUTRAL
 2: PERMANENT LIVE - CLOSE
 3: SWITCHED LIVE - OPEN

3 POINT CONTROL : ON/OFF

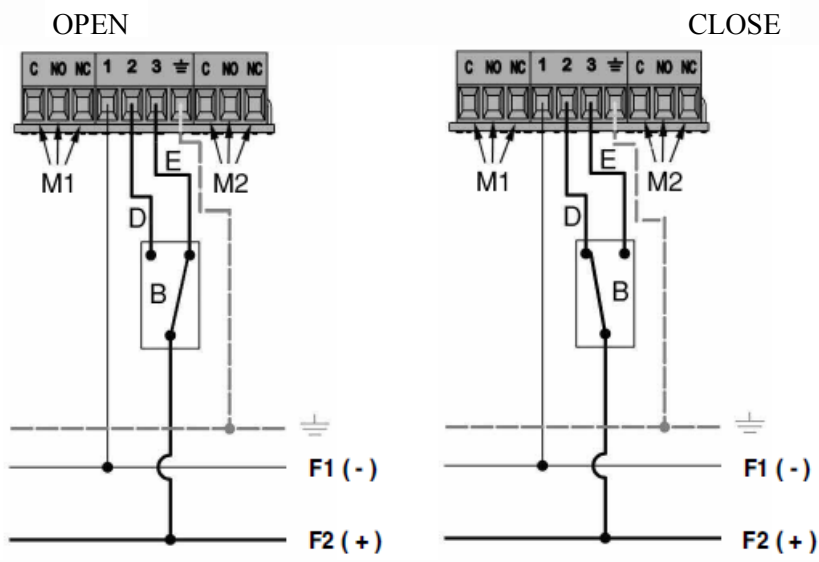

B:
 SWITCH
 D: CLOSE
 E:: OPEN

C: COMMON
 NO: NORMALLY OPEN
 NC: NORMALLY

1 NEUTRAL
 2 LIVE - CLOSE
 3 LIVE - OPEN

The 12vAC/DC and 24vAC/DC units can be used with a 3 point or 2 point connection without having to change jumpers. It is possible to use the Compact DC PRO with both AC and DC power supplies. When using a DC power supply its not possible to reverse the polarity of the two phases. Although no damage will be caused, the actuator will not function. The Compact DC PRO is available in 12vAC/DC and 24vAC/DC options. It is essential to use the correct voltage with the corresponding actuator.

V-FLOW

SOLUTIONS LTD

V-Flow Solutions Ltd, 12 Railton Road, Woburn Road Industrial Estate
Kempston, Bedford MK42 7PW, England

Tel: +44 (0)1234 855888 Fax: +44 (0)1234 857775
Email: sales@v-flowsolutions.co.uk Website: www.v-flowsolutions.co.uk