

Model: 3254 Automatic Water Pump Control

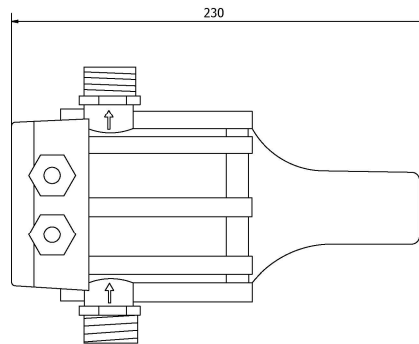

FEATURES

- Input voltage 220V-240V 50/60Hz.
- Max. current 10(6)A.
- Pump maximum power 1,5HP (1,1kw).
- Protection grade IP65.
- Maximum working pressure 10 bar (1MPa).
- Starting pressure 1,5 bar (0,15 MPa).
- Maximum working temperature 60° C.
- Connections R1" (ISO 7/1).

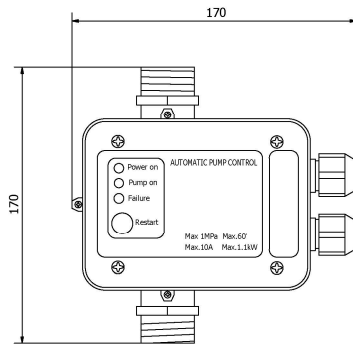

Ref.	Size	PN	Starting pressure (bar)	Pump's pressure	The height of water column (H)	Weight (g)
3254	1"	10	1,5 (0,15 MPa)	≥ 1,5 bar (0,15 MPa)	≤ 15 m	1120

DESCRIPTION

The control is programmed to start and stop a pump operations automatically.
 Its feature of water-shortage protection can protect the pump from being damaged during dry running.

INSTALLATION INSTRUCTIONS

1. The control can be installed directly on the pump or installed between pump and the first tap.
2. A pressure reducing valve must be installed on the inlet of the control if pump's pressure exceeds 10 bar.
3. No taps can be installed between the pump and the control.
4. It is imperative to install the control with the arrows in the upward position.
5. It is advisable to connect the control outlet to the system by means of a flexible pipe.
6. Safety valve is installed inside the controller to prevent water emission in case of diaphragm breaks.
7. Check suction and ensure that the pump is primed before starting the control.
8. Normally pressure produced by the pump must be 1 bar (0,1MPa) higher than the control's pre- set pressure, that is, checking on the effective pressure of pump and system water column height must be carried out according to the pre- set pressure.
9. The pump can be blocked or continues to operate without stop if its pressure is lower than stated minimum pressure. On the other hand, the pump will not work if the height of water column exceeds above standards. It is advisable to install the unit on a higher level to restore a good installation condition as mentioned in the above or to change for a unit with larger starting pressure.

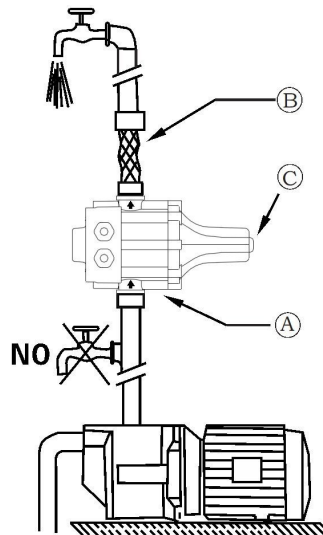
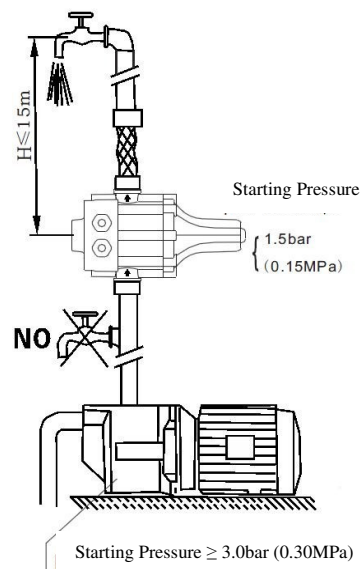

Fig1



DISPLAY & OPERATION

When the control is connected to the electrical network, the green LED "power on" lights up and the yellow LED "on" (pump in operation) lights 2-4s later indicating that the pump has been started. The pump continues to operate for 8s enabling the system to fill in the pipes and to reach the required pressure.

If this lapse is insufficient, the red LED "failure" lights up. In this event, keep the "restart" button pressed and wait with a tap opened until the red LED is off. Once the button is released and the tap is closed, the control stops the pump at its max. pressure.

CAUTION

1. Never take the electronic board out of the control box.
2. The wiring diagram inside the terminal block will show you a correct connection. Wrong or loose connection will destroy the whole electronic circuit.
3. Cable used for connection must be H05 or H07 type with 3 x 1,5 mm² section and it shall have the outer diameter at 8,9 mm minimum - 9,2 mm maximum. One of the leading end of the cable must be lower than the position of the fixing screws while the cable being connected to the power as shown in the fig.
4. The six screws on the panel board and the two nuts for fixing cable must be well fastened to avoid water entering into the control box and damaging the electronic circuit.
5. Always cut off the power before maintenances and repairs.
6. If the system is used in swimming pools, gardens or surroundings like this, an appropriate circuit- breaker (RCD) must be installed before connection to the pump. Pressure control and the attached plug and socket shall not be put in places subject to flooding or rain.
7. If want to remove the controller after the pump stop, open the nearest faucet to relieve the pressure conserved in the pipe-line.

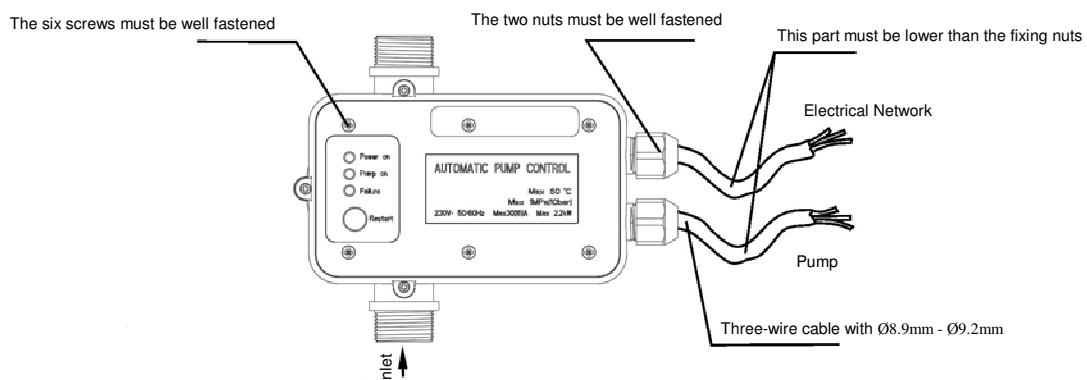

Wiring Diagrams

Wiring diagram to connect 230 V single phase pumps up to 1.1 kW (1,5 HP).

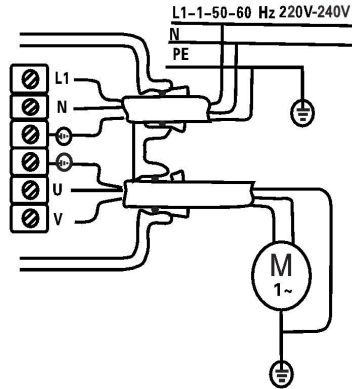

Wiring diagram to connect 230 V single-phase pumps over 1.1 kW (1,5 HP) through a contactor switching. (Specifications for main contactor: Minimum capacity of 4 kW or contact approx 5.5 Hp, 230 V).

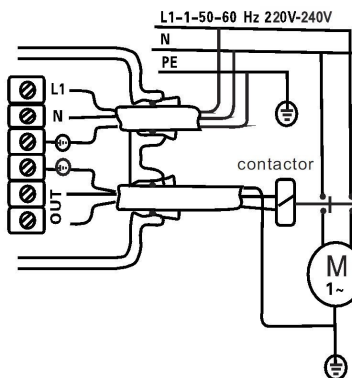

Wiring diagram for connecting three-phase 380 V pumps through a contactor switching. (Specifications for main contactor: Minimum capacity of 4 kW or contact approx 5.5 Hp, 230 V).

