

B203/204/205/206/222 Series, General Purpose – 2/2 Normally Closed

Specifications	
Function (single acting)	 <p>Flow direction overseat 1 → 2</p>
Maximum Viscosity	Max. 21cST (3 °E)
Body Material (Std)	Brass CW617N (EN 12165)
Flange	Stainless Steel 1.4305 EN 10088 (AISI 303)
Tube	Stainless Steel AISI 304
Plunger and Top Stop	Stainless Steel 1.4105 EN 10088 (AISI 430F) or equivalent
Springs	Stainless Steel AISI 302
Seal Material (Std)	NBR
Connection Type (Std)	G parallel thread (ISO 228-1)
Shading Ring	Copper
Electrical Characteristics	
Standard Coil Voltage DC (=)	24 V
Standard Coil Voltage AC 50 Hz (~)	24 V, 110 V, 200 V, 230 V
Standard Coil Voltage AC 60 Hz (~)	24 V, 120 V, 220 V, 240 V
Voltage Tolerance	+10% to -15% (AC)
	+10% to -5% (DC)
Duty Cycle	100% ED
Protection Class	IP65 (EN 60529) with plug and gasket correctly fitted *
Electrical Connection	to industrial form B
Coil Insulation	Class F 155 °C
Power Rating (Standard)	AC 10 VA (holding) AC 16 VA (inrush) DC 7 W

Features and Benefits

- Pilot operated
- Robust construction for industrial applications
- Stainless steel AISI 430F operators with low residual magnetism
- Coils tested 100% in compliance to RoHS directive and to relevant international standards
- Choice of high quality seal materials
- Response time 50 to 500 ms

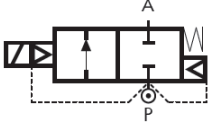

Pipe Size	Cv (gpm)	Kv (m³/h)	OPD (bar)		Orifice (mm)	Seal Material	Valve Code
			AC Voltages	DC Voltages			
¼"	1.83	1.56	0.3 - 16	0.3 - 16	13	NBR	B203DBZ
¾"	3.86	3.30				FKM	B203DVZ
						EPDM	B203DEZ
½"	4.42	3.78			NBR	B204DBZ	
					FKM	B204DVZ	
¾" compact	7.02	6.00			EPDM	B204DEZ	
			NBR	B205DBZ			
¾"	9.83	8.40	FKM	B205DVZ			
			EPDM	B205DEZ			
1"	11.23	9.60	25	NBR	B206DBX		
				FKM	B206DVX		
				EPDM	B206DEX		
1"	11.23	9.60	25	FNBR	B206DBY ¹		
				FKM	B206D ^Y Y ¹		
				EPDM	B206DE ^Y Y ¹		
1"	11.23	9.60	25	NBR	B222DBY		
				FKM	B222D ^Y Y		
				EPDM	B222DE ^Y Y		

¹ Non standard, MOQ required.

Options Available

Valve Options (see coding chart)
NPT threads (minimum batch may be required)
Manual override
Electroless nickel plating treatment
Speed control screw (on DN25 only)

Seal Material ¹ and Media Temperature Range	Media	Ambient Temperature Range	
		Min	Max
NBR (-10 °C to +90 °C)	Water, oil, air	-10 °C	+50 °C
FKM (-10 °C to +130 °C)	Water, oil, air	-10 °C	+50 °C
EPDM (-10 °C to +120 °C)	Water, hot water	-10 °C	+50 °C

¹ See corrosion reference guide and sealing solutions for material compatibility.

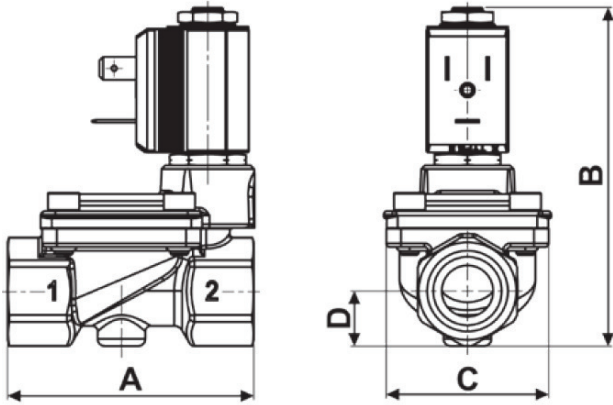
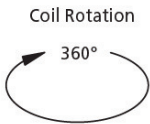

Preferred Valve Mounting Options



Pipe Size	A	B	C	D	Weight (kg)
¼" - ⅜" - ½"	67	90	45.6	15	0.4
¾" compact	82	105	51.6	20.25	0.6
¾" to 1"	96	115	72	23	1.2

Dimensions (mm)

Solenoid enclosures

2--0 Type Coil - Insulation class F

- External material: PBT (reinforced fiberglass 30%)
 Electrical connection: Industrial form B
 Winding insulation: Class H (E180)
 Enclosure classification: Conforms to IP65 (according to EN 60529) with plug and gasket correctly fitted*



Type 600 001- Plug

- Rated Voltage (max.): 250 VAC / 300 VDC
 Nominal Current: 10A (rated) / 16A (max)
 Wire cross-section: 1.5 mm² max
 Cable Entry: PG9 (6 to 8 mm)
 Enclosure classification: Conforms to IP65 (according to EN 60529) with supplied gasket
 Insulation class: group C- VDE 0110
 Housing colour: black
 UL approved, file No: E205538



* Plug and gasket not supplied as standard, must be ordered separately.

Coding chart

Main Valve Assembly

Pipe Size
03 ¼"
04 ⅜"
05 ½"
06 ¾" (compact)
06 ¾" 1
22 1"

Seals	Orifice ²
B NBR	Z 13
V FKM	X 21
E EPDM	Y 25

Option
N NPT
M Manual Override
K Electroless nickel plating
V Speed control screw ³
w/o option

Coil options

Voltage / Frequency - Class F	
2250	24 VDC
2200	24 V / 50/60 Hz
2400	110 V / 50 Hz - 120 V / 60 Hz
2600	200 V / 50 Hz - 220 V / 60 Hz
2700	230 V / 50 Hz - 240 V / 60 Hz

Plug

Plug
w/o plug
0B1 c/w plug



¹ Non standard, MOQ required.
² DN13 only for B203/204/205, DN21 only for B206 compact, DN25 only for B206 and B222.
³ Speed control screw available on B206D-Y and B222D-Y.

Product coding example:

B203DBZ 2250
 ¼" G, auto operation, brass body, NBR seals, 13 mm orifice, 24 VDC, without plug.

D223/224/225 Series, General Purpose – 2/2 Normally Closed

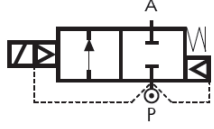
Specifications	
Function (single acting)	 <p>Flow direction overseat 1 → 2</p>
Maximum Viscosity	Max. 21cST (3 °E)
Body Material (Std)	Brass CW617N (EN 12165)
Flange	Stainless Steel 1.4305 EN 10088 (AISI 303)
Tube	Stainless Steel AISI 304
Plunger	Stainless Steel 1.4106 EN 10088 (AISI 430F)
Top Stop	Stainless Steel 1.4105 EN 10088 (AISI 430F)
Springs	Stainless Steel AISI 302
Seal Material (Std)	NBR
Connection Type (Std)	G parallel thread (ISO 228-1)
Shading Ring	Copper
Electrical Characteristics	
Standard Coil Voltage DC (=)	24 V
Standard Coil Voltage AC 50 Hz (~)	24 V, 110 V, 200 V, 230 V
Standard Coil Voltage AC 60 Hz (~)	24 V, 120 V, 220 V, 240 V
Voltage Tolerance	+10% to -15% (AC)
	+10% to -5% (DC)
Duty Cycle	100% ED
Protection Class	IP65 (EN 60529) with plug and gasket correctly fitted *
Electrical Connection	to EN 175301 - 803 - A (ex DIN 43650)
Coil Insulation	Class F 155 °C
Power Rating (Standard)	AC 18 VA (holding) AC 36 VA (inrush) DC 14 W

Features and Benefits

- Pilot operated
- Robust construction for industrial applications
- Stainless steel AISI 430F operators with low residual magnetism
- Coils tested 100% in compliance to RoHS directive and to relevant international standards
- Choice of high quality seal materials
- Speed control screw as standard
- Response time 50 to 500 ms



Pipe Size	Cv (gpm)	Kv (m³/h)	OPD (bar)		Orifice (mm)	Seal Material	Valve Code
			AC Voltages	DC Voltages			
1 ¼"	25.97	22.20	0.5 - 16	0.5 - 16	40	NBR	D223DBK
						FKM	D223DVK
					EPDM	D223DEK	
1 ½"	28.08	24.00			40	NBR	D224DBK
						FKM	D224DVK
					EPDM	D224DEK	
2"	37.91	32.40			50	NBR	D225DBJ
						FKM	D225DVJ
						EPDM	D225DEJ

Options Available

Valve Options (see coding chart)
NPT threads (minimum batch may be required)
Manual override
Electroless nickel plating

Vacuum Version
See separate datasheet

Seal Material ¹ and Media Temperature Range	Media	Ambient Temperature Range	
		Min	Max
NBR (-10 °C to +90 °C)	Water, oil, air	-10 °C	+50 °C
FKM (-10 °C to +130 °C)	Water, oil, air	-10 °C	+50 °C
EPDM (-10 °C to +120 °C)	Water, hot water	-10 °C	+50 °C

¹ See corrosion reference guide and sealing solutions for material compatibility.

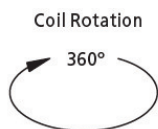

Preferred Valve Mounting Options

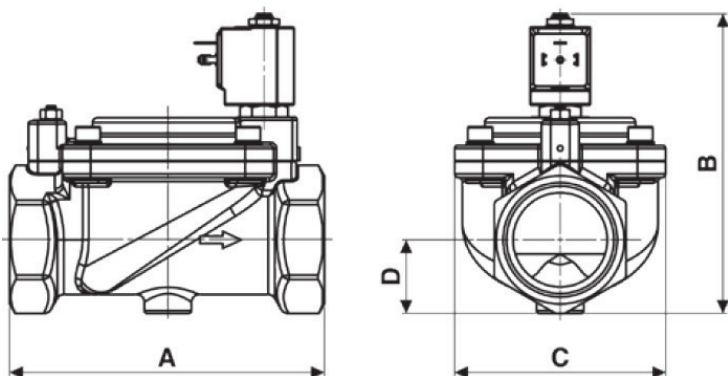

Pipe Size	A	B	C	D	Weight (kg)
1 ¼" - 1 ½"	140	140	96	31.5	2.8
2"	167	158	112	39	3.9

Dimensions (mm)

Solenoid enclosures

7--0 Type Coil - Insulation class F

- External material: PBT (reinforced fiberglass 30%)
- Electrical connection: DIN EN 175301-803 form A
- Winding insulation: Class H (E180)
- Enclosure classification: Conforms to IP65 (according to EN 60529) with plug and gasket correctly fitted*



Type 600 011- Plug

- Rated Voltage (max.): 250 VAC / 300 VDC
- Nominal Current: 10A (rated) / 16A (max)
- Wire cross-section: 1.5 mm² max
- Cable Entry: PG9 (6 to 8 mm)
- Enclosure classification: Conforms to IP65 (according to EN 60529) with supplied gasket
- Insulation class: group C- VDE 0110
- Housing colour: black
- UL approved, file No: E205538



* Plug and gasket not supplied as standard, must be ordered separately.

Coding chart

Main Valve Assembly

Pipe Size
23 1 ¼"
24 1 ½"
25 2"

Seals	Orifice ¹
B NBR	K 40
V VKM	J 50
E EPDM	

Option
N NPT
K Electroless nickel plating
w/o option

Voltage / Frequency - Class F
7250 24 VDC
7200 24 V / 50/60 Hz
7400 110 V / 50 Hz - 120 V / 60 Hz
7600 200 V / 50 Hz - 220 V / 60 Hz
7700 230 V / 50 Hz - 240 V / 60 Hz

Plug
w/o plug
0A1 c/w plug

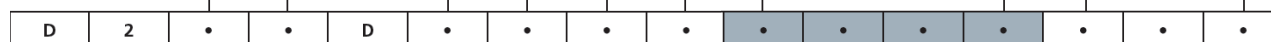

¹ DN40 only for D223 and D224, DN50 only for D225.

Product coding example:

D223DBK 7250
1 ¼" G, auto operation, brass body, NBR seals, 40 mm orifice, 24 VDC, without plug.

RB203/204/205/206/222 Series, General Purpose – 2/2 Normally Open

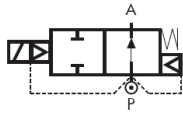
Specifications	
Function (single acting)	 <p>Flow direction overseat 1 → 2</p>
Maximum Viscosity	Max. 21cST (3 °E)
Body Material (Std)	Brass CW617N (EN 12165)
Flange Tube ¹	Brass CW614N (EN 12164)
Plunger and Top Stop	Stainless Steel 1.4105 EN 10088 (AISI 430F) or equivalent
Springs	Stainless Steel AISI 302
Seal Material (Std)	NBR
Connection Type (Std)	G parallel thread (ISO 228-1)
Shading Ring	Copper
Electrical Characteristics	
Standard Coil Voltage DC (=)	24 V
Standard Coil Voltage AC 50 Hz (~)	24 V, 110 V, 200 V, 230 V
Standard Coil Voltage AC 60 Hz (~)	24 V, 120 V, 220 V, 240 V
Voltage Tolerance	+10% to -15% (AC)
	+10% to -5% (DC)
Duty Cycle	100% ED
Protection Class	IP65 (EN 60529) with plug and gasket correctly fitted *
Electrical Connection	to industrial form B
Coil Insulation	Class F 155 °C
Power Rating (Standard)	AC 10 VA (holding) AC 16 VA (inrush) DC 7 W

Features and Benefits

- Pilot operated
- Robust construction for industrial applications
- Stainless steel AISI 430F operators with low residual magnetism
- Coils tested 100% in compliance to RoHS directive and to relevant international standards
- Choice of high quality seal materials
- Response time 50 to 500 ms



Pipe Size	Cv (gpm)	Kv (m³/h)	OPD (bar)		Orifice (mm)	Seal Material	Valve Code
			AC Voltages	DC Voltages			
¼"	1.83	1.56	0.3 - 16	0.3 - 16	13	NBR	RB203DBZ
¾"	3.86	3.30				FKM	RB203DYZ
						EPDM	RB203DEZ
½"	4.42	3.78			NBR	RB204DBZ	
					FKM	RB204DYZ	
¾" compact	7.02	6.00			EPDM	RB204DEZ	
			NBR	RB205DBZ			
¾"	9.83	8.40	21	25	NBR	RB206DBX	
					FKM	RB206DYX	
					EPDM	RB206DEX	
FNBR	RB206DBY ²						
1"	11.23	9.60			FKM	RB206DY ²	
					EPDM	RB206DEY ²	
1"	11.23	9.60	25	25	NBR	RB222DBY	
					FKM	RB222DY	
1"	11.23	9.60	25	25	EPDM	RB222DEY	

¹ With special brass nut for NO operator (different from Standard).

² Non standard, MOQ required.

Options Available

Valve Options (see coding chart)
NPT threads (minimum batch may be required)
Electroless nickel plating treatment
Speed control screw

Seal Material ³ and Media Temperature Range	Media	Ambient Temperature Range	
		Min	Max
NBR (-10 °C to +90 °C)	Water, oil, air	-10 °C	+50 °C
FKM (-10 °C to +130 °C)	Water, oil, air	-10 °C	+50 °C
EPDM (-10 °C to +120 °C)	Water, hot water	-10 °C	+50 °C

³ See corrosion reference guide and sealing solutions for material compatibility.

Preferred Valve Mounting Options

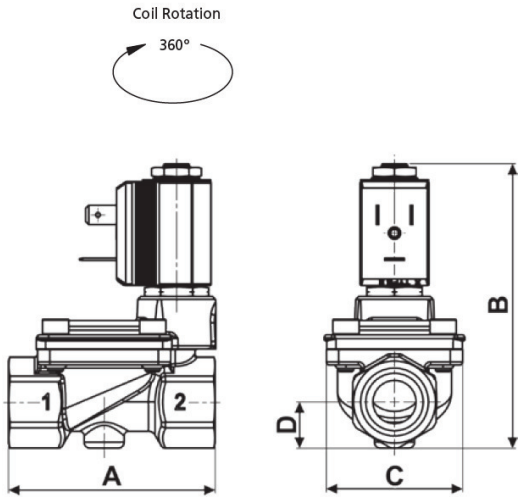

Pipe Size	A	B	C	D	Weight (kg)
1/4" - 3/8" - 1/2"	67	92.5	45.6	15	0.4
3/4" compact	82	107.5	51.6	20.25	0.6
3/4" to 1"	96	117.5	72	23	1.2

Dimensions (mm)

Solenoid enclosures

2--0 Type Coil - Insulation class F

External material: PBT (reinforced fiberglass 30%)
 Electrical connection: Industrial form B
 Winding insulation: Class H (E180)
 Enclosure classification: Conforms to IP65 (according to EN 60529) with plug and gasket correctly fitted*



Type 600 001- Plug

Rated Voltage (max.): 250 VAC / 300 VDC
 Nominal Current: 10A (rated) / 16A (max)
 Wire cross-section: 1.5 mm² max
 Cable Entry: PG9 (6 to 8 mm)
 Enclosure classification: Conforms to IP65 (according to EN 60529) with supplied gasket
 Insulation class: group C- VDE 0110
 Housing colour: black
 UL approved, file No: E205538



* Plug and gasket not supplied as standard, must be ordered separately.

Coding chart

Main Valve Assembly

Pipe Size	
03	1/4"
04	3/8"
05	1/2"
06	3/4" (compact)
06	3/4" 1
22	1"

Seals	Orifice ²
B NBR	Z 13
V FKM	X 21
E EPDM	Y 25

Option	
N	NPT
K	Electroless nickel plating
V	Speed control screw ³
	w/o option

Coil options

Voltage / Frequency - Class F	
2250	24 VDC
2200	24 V / 50/60 Hz
2400	110 V / 50 Hz - 120 V / 60 Hz
2600	200 V / 50 Hz - 220 V / 60 Hz
2700	230 V / 50 Hz - 240 V / 60 Hz

Plug

Plug	
	w/o plug
0B1	c/w plug

RB	2	.	.	D
----	---	---	---	---	---	---	---	---	---	---	---	---	---	---

¹ Non standard, MOQ required.
² DN13 only for RB203/204/205, DN21 only for RB206 compact, DN25 only for RB206 and RB222.
³ Speed control screw available on RB206D-Y and RB222D-Y.

Product coding example:

RB203DBZ 2250
 1/4" G, auto operation, brass body, NBR seals, 13 mm orifice, 24 VDC, without plug.

RD223/224/225 Series, General Purpose – 2/2 Normally Open

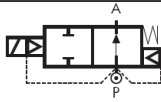
Specifications	
Function (single acting)	 <p>Flow direction overseat 1 → 2</p>
Maximum Viscosity	Max. 21cST (3 °E)
Body Material (Std)	Brass CW617N (EN 12165)
Flange Tube	Stainless Steel 1.4305 EN 10088 (AISI 303)
Plunger	Stainless Steel 1.4106 EN 10088 (AISI 430F)
Top Stop	Stainless Steel 1.4105 EN 10088 (AISI 430F)
Springs	Stainless Steel AISI 302
Seal Material (Std)	NBR
Connection Type (Std)	G parallel thread (ISO 228-1)
Shading Ring	Copper
Electrical Characteristics	
Standard Coil Voltage DC (=)	24 V
Standard Coil Voltage AC 50 Hz (-)	24 V, 110 V, 200 V, 230 V
Standard Coil Voltage AC 60 Hz (-)	24 V, 120 V, 220 V, 240 V
Voltage Tolerance	+10% to -15% (AC)
	+10% to -5% (DC)
Duty Cycle	100% ED
Protection Class	IP65 (EN 60529) with plug and gasket correctly fitted *
Electrical Connection	to EN 175301 - 803 - A (ex DIN 43650)
Coil Insulation	Class H 180 °C
Power Rating (Standard)	AC 18 VA (holding) AC 36 VA (inrush) DC 14 W

Features and Benefits

- Pilot operated
- Robust construction for industrial applications
- Stainless steel AISI 430F operators with low residual magnetism
- Coils tested 100% in compliance to RoHS directive and to relevant international standards
- Choice of high quality seal materials
- Troublefree operation with coils class H
- Speed control screw as standard
- Response time 50 to 500 ms



Pipe Size	Cv (gpm)	Kv (m³/h)	OPD (bar)		Orifice (mm)	Seal Material	Valve Code
			AC Voltages	DC Voltages			
1 ¼"	25.97	22.20	0.5 - 16	0.5 - 16	40	NBR	RD223D B K
						FKM	RD223D V K
1 ½"	28.08	24.00	0.5 - 16	0.5 - 16	40	EPDM	RD223D E K
						NBR	RD224D B K
2"	37.91	32.40	0.5 - 16	0.5 - 16	50	FKM	RD224D V K
						EPDM	RD224D E K
2"	37.91	32.40	0.5 - 16	0.5 - 16	50	NBR	RD225D B J
						FKM	RD225D V J
2"	37.91	32.40	0.5 - 16	0.5 - 16	50	EPDM	RD225D E J
						NBR	RD225D B J

Options Available

Valve Options (see coding chart)
NPT threads (minimum batch may be required)
Electroless nickel plating

Seal Material ¹ and Media Temperature Range	Media	Ambient Temperature Range	
		Min	Max
NBR (-10 °C to +90 °C)	Water, oil, air	-10 °C	+50 °C
FKM (-10 °C to +130 °C)	Water, oil, air	-10 °C	+50 °C
EPDM (-10 °C to +120 °C)	Water, hot water	-10 °C	+50 °C

¹ See corrosion reference guide and sealing solutions for material compatibility.

Coil Rotation

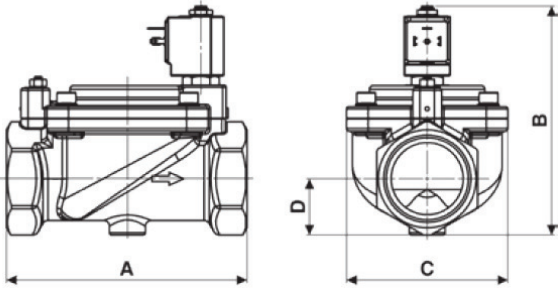

Preferred Valve Mounting Options



Pipe Size	A	B	C	D	Weight (kg)
1 ¼" - 1 ½"	140	140	96	31.5	2.8
2"	167	158	112	39	3.9

Dimensions (mm)

Solenoid enclosures

7--1 Type Coil - Insulation class H

- External material: PPS (glass fiber & mineral filled)
- Electrical connection: DIN EN 175301-803 form A
- Winding insulation: Class H (E180)
- Enclosure classification: Conforms to IP65 (according to EN 60529) with plug and gasket correctly fitted*



Type 600 011- Plug

- Rated Voltage (max.): 250 VAC / 300 VDC
- Nominal Current: 10A (rated) / 16A (max)
- Wire cross-section: 1.5 mm² max
- Cable Entry: PG9 (6 to 8 mm)
- Enclosure classification: Conforms to IP65 (according to EN 60529) with supplied gasket
- Insulation class: group C- VDE 0110
- Housing colour: black
- UL approved, file No: E205538



* Plug and gasket not supplied as standard, must be ordered separately.

Coding chart

Main Valve Assembly

Pipe Size
23 1 ¼"
24 1 ½"
25 2"

Seals	Orifice ¹
B NBR	K 40
V VKM	J 50
E EPDM	

Option
N NPT
K Electroless nickel plating
w/o option

Coil options

Voltage / Frequency - Class H	
7251	24 VDC
7201	24 V / 50/60 Hz
7401	110 V / 50 Hz - 120 V / 60 Hz
7601	200 V / 50 Hz - 220 V / 60 Hz
7701	230 V / 50 Hz - 240 V / 60 Hz

Plug

Plug
w/o plug
0A1 c/w plug



¹ DN40 only for RD223 and RD224 only, DN50 only for RD225.

Product coding example:

RD223DBK 7251
1 ¼" G, auto operation, brass body, NBR seals, 40 mm orifice, 24 VDC, without plug.