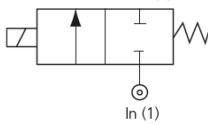

# 68 Series: Cryogenic – 2/2 Normally Closed

Specifications	
Function	Normally Closed, energise to open, Out (2)  In (1)
Maximum Viscosity	65cST
1/4" - 1" Body Material	Brass (CZ122)
1 1/4" - 2" Body Material	Bronze
Flange Tube	Stainless Steel 303
Plunger and top stop	Stainless Steel 430FR
Springs	Stainless Steel 302
Seal Material (Std)	PTFE
Connection Type (Std)	BS21
Shading Ring	Copper (Std), Silver (stainless steel option)
Electrical Characteristics	
Coil Voltage DC (=)	12 V, 24 V, 110 V
Coil Voltage AC 50 Hz (-)	24 V, 110 V, 120 V, 230 V
Coil Voltage AC 60 Hz (-)	24 V, 110 V, 120 V, 220 V
Voltage Tolerance	+10% or -10%
Duty Cycle	100% ED
Protection Class (Std)	IP65 (BS EN 60529) (plug supplied as standard)
Electrical Connection (Std)	PG9 Din Connector DIN 43650/ISO 4400 (EN 175301-803) Form 'A'
Coil Insulation	Class H (BS EN 60085) 180 °C
Power Rating	14.5 Watts, 19 VA

## Features and Benefits

- Controls Cryogenic Media down to -196 °C
- Larger Porting for High Kv
- Teflon® - PTFE seals
- Choice of Brass or Stainless steel valve body

## Special Features

- Oxygen Degreased and individually packed for use on liquids down to -196 °C



Pipe Size	Cv (gpm)	Kv (m³/h)	OPD (Bar)		P. Max Bar	Orifice (mm)	Weight (kg)
			AC Voltages	DC Voltages			
1/4"	0.52	0.43	0-8.0	0-6	50	4.50	0.35
1/4"	0.60	0.52	0-8.6	0-6		6.0	0.35
3/8"	3.5	3.0	0.3-8.6	0.3-6		16.00	1.20
1/2"	4.9	4.2	0.3-8.6	0.3-6		16.00	1.20
3/4"	6.3	5.4	0.3-8.6	0.3-6		16.00	1.20-2.30
1"	8.24	7.1	0.3-8.6	0.3-6		25.00	1.20-2.30
1 1/4"	20.9	18	0.3-8.6	0.3-6		32.00	3.10
1 1/2"	20.9	18	0.3-8.6	0.3-6		32.00	3.10
2"	20.9	18	0.3-8.6	0.3-6		32.00	5.20

## How to use the flow chart

1. Select the required flow.
2. Note the corresponding pressure drop.
3. Based on where the two points intersect select the most appropriate model.

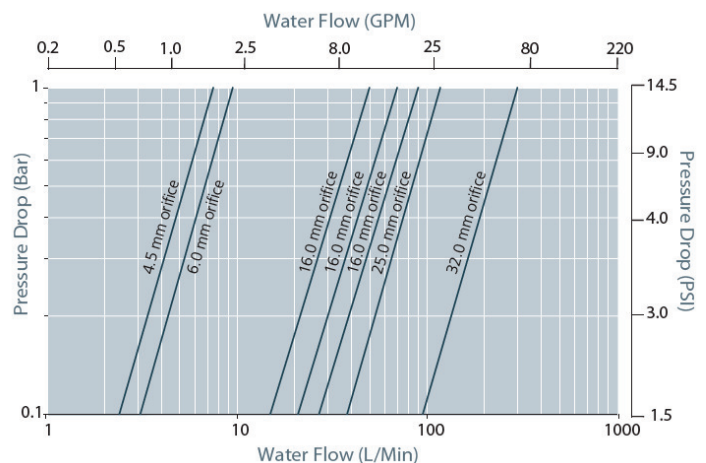

## Options Available

Exd Solenoid Enclosure		
Protection Class	Consult Rotork Midland for product codes	
EExd T6 (IP67)		
Seal Material <sup>1</sup> and Media Temp. Range	Ambient Temperature Range °C	
	Min	Max
PTFE (-200 °C to +180 °C)	-10	50
Main Valve Body Options		
Stainless Steel body 316 (available up to and including 1 inch)		
NPT Threads		
Stainless Steel Tagging (consult factory for product code)		

<sup>1</sup> See corrosion reference guide and sealing solutions for material compatibility.

Preferred Valve Mounting Options

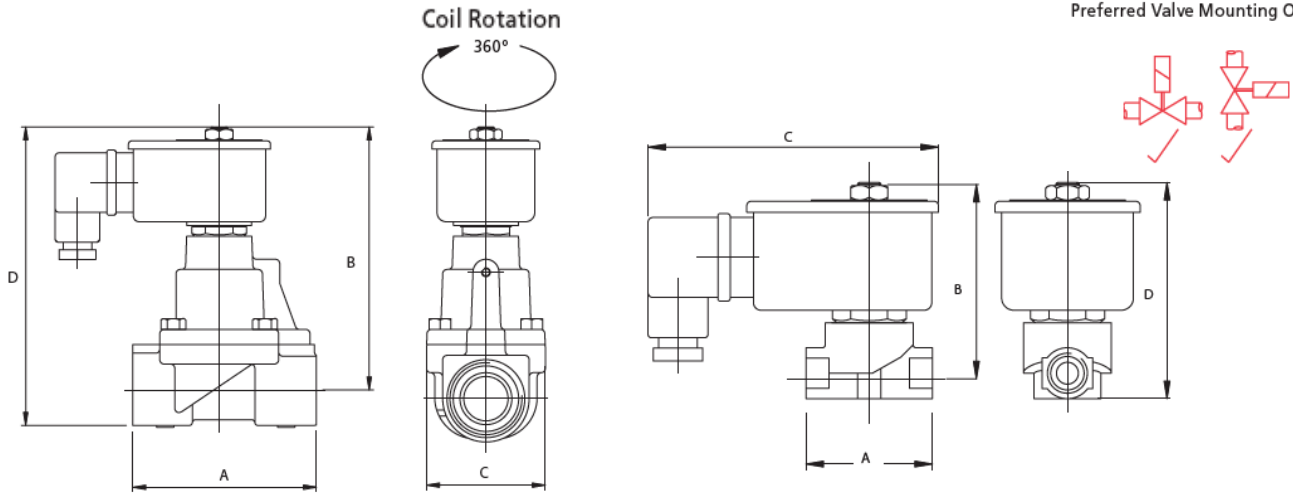

Pipe Size	A	B	C	D
3/8" - 1/2"	85	105	105*	122
3/4" - 1"	85	135	105*	155
1 1/4" - 1 1/2"	117	133	82.5	209
2"	146	145	103	209

Pipe Size	A	B	C	D
1/4"	44	70	105	78

Dimensions given in mm  
\* Dimensions including Din Plug

Solenoid enclosures



S4 Type enclosure protection class IP50

- External material: Pressed steel powder coated
- Electrical entry: Conduit boss 20 mm or 1/2" NPT
- Electrical connection: Screwed terminals or 0.5 mm flying leads, or DIN connector for cryogenic applications
- Winding insulation: Class H

Coding chart

Main Valve Assembly

Model	Valve Body Conn. Size	Connection Type	Operation	Orifice (mm)	Body Material	Seals	Style
37   68 Series	B 1/4" C 3/8" D 1/2" E 3/4" F 1" G 1 1/4" H 1 1/2" J 2"	1 BS21 2 BSP G (1 1/4" and above) 3 NPT	1 AUTO	H 4.5 J 6.0 Z Default	1 Brass (standard on valves up to and including 1") 2 Bronze (standard on valves above 1") 5 316 Stainless Steel (option available up to and inc 1")	E PTFE	1 Standard

Coil options

Enclosure	Voltage / Frequency	Electrical Connection
2 S4 type enclosure metal can	E2 230 V / 50 Hz H2 110 V / 50 Hz & 120 V / 60 Hz F1 24 VDC	1 DIN plug 9 mm

37	.	.	1	.	.	E	1	-	2	..	1
----	---	---	---	---	---	---	---	---	---	----	---

Product coding example:

37C11Z1E1-2E21 - 68 Series cryogenic  
3/8" BS21, auto operation, brass body, PTFE seals, S4 enclosure 230 V / 50 Hz DIN Plug 9 mm.