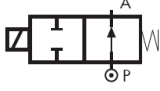

RB297 Series, Automation – 2/2 Normally Open

Specifications	
Function (single acting)	 <p>Flow direction overseat 1 → 2</p>
Maximum Viscosity	Max. 21cST (3 °E)
Body Material (Std)	Low lead content Brass CW719R (EN 12165)
Orifice Material	Stainless Steel 1.4305 EN 10088 (AISI 303)
Flange Tube ¹	Brass CW614N (EN 12164)
Plunger and Top Stop	Stainless Steel 1.4105 EN 10088 (AISI 430F) or equivalent
Springs	Stainless Steel AISI 302
Seal Material (Std)	Foodgrade FKM
Connection Type (Std)	G parallel thread (ISO 228-1)
Shading Ring	Copper
Electrical Characteristics	
Standard Coil Voltage DC (=)	24 V
Standard Coil Voltage AC 50 Hz (~)	24 V, 110 V, 200 V, 230 V
Standard Coil Voltage AC 60 Hz (~)	24 V, 120 V, 220 V, 240 V
Voltage Tolerance	+10% to -15% (AC)
	+10% to -5% (DC)
Duty Cycle	100% ED
Protection Class	IP65 (EN 60529) with plug and gasket correctly fitted *
Electrical Connection	to industrial form B
Coil Insulation	Class F 155 °C
Power Rating (Standard)	AC 10 VA (holding) AC 16 VA (inrush) DC 7W

¹ With special nut for NO operator (different from Standard).

Options Available

Valve Options
NPT threads (minimum batch may be required)
Electroless nickel plating treatment

Features and Benefits

- Direct Acting
- Robust construction for industrial applications
- Stainless steel AISI 430F operators with low residual magnetism
- Coils tested 100% in compliance to RoHS directive and to relevant international standards
- High quality seal materials
- Response time 5 to 25 ms
- Valve suitable for contact with food media as per EEC Directives and Regulations. Please consult supplier for more details.



Pipe Size	Cv (gpm)	Kv (m ³ /h)	OPD (bar)		Orifice (mm)	Seal Material	Valve Code
			AC Voltages	DC Voltages			
1/8"	0.04	0.03	0 - 25	0 - 25	1.0	FKM EPDM	RB297DVA RB297DEA
1/8"	0.05	0.04	0 - 20	0 - 20	1.2	FKM EPDM	RB297DVB RB297DEB
1/8"	0.07	0.06	0 - 15	0 - 15	1.5	FKM EPDM	RB297DVC RB297DEC
1/8"	0.12	0.10	0 - 10	0 - 10	2.0	FKM EPDM	RB297DVE RB297DEE
1/8"	0.16	0.14	0 - 5	0 - 5	2.5	FKM EPDM	RB297DVG RB297DEG
1/8"	0.21	0.18	0 - 4.5	0 - 4.5	3.0	FKM EPDM	RB297DVH RB297DEH

Seal Material ¹ and Media Temperature Range	Media	Ambient Temperature Range	
		Min	Max
FKM (-10 °C to +130 °C)	Water, oil, air	-10 °C	+50 °C
EPDM (-10 °C to +120 °C)	Water, hot water	-10 °C	+50 °C

¹ See corrosion reference guide and sealing solutions for material compatibility.

Coil Rotation

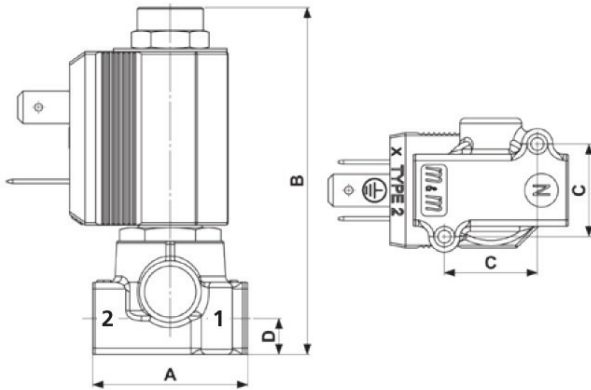

Preferred Valve Mounting Options



Pipe Size	A	B	C	D	Weight (kg)
1/8"	30	67.5	18	7	0.15

Dimensions (mm)

Solenoid enclosures

2--0 Type Coil - Insulation class F

- External material: PBT (reinforced fiberglass 30%)
- Electrical connection: Industrial form B
- Winding insulation: Class H (E180)
- Enclosure classification: Conforms to IP65 (according to EN 60529) with plug and gasket correctly fitted*



Type 600 001- Plug

- Rated Voltage (max.): 250 VAC / 300 VDC
- Nominal Current: 10A (rated) / 16A (max)
- Wire cross-section: 1.5 mm² max
- Cable Entry: PG9 (6 to 8 mm)
- Enclosure classification: Conforms to IP65 (according to EN 60529) with supplied gasket
- Insulation class: group C- VDE 0110
- Housing colour: black
- UL approved, file No: E205538



* Plug and gasket not supplied as standard, must be ordered separately.

Coding chart

Main Valve Assembly

Coil options

Plug

Seals		Orifice		Option		Voltage / Frequency - Class F		Plug	
V	FKM	A	1.0	N	NPT	2250	24 VDC		w/o plug
E	EPDM	B	1.2	K	Electroless nickel plating	2200	24 V / 50/60 Hz	0B1	c/w plug
		C	1.5		w/o option	2400	110 V / 50 Hz - 120 V / 60 Hz		
		E	2.0			2600	200 V / 50 Hz - 220 V / 60 Hz		
		G	2.5			2700	230 V / 50 Hz - 240 V / 60 Hz		
		H	3.0						

RB	2	9	7	D
----	---	---	---	---	---	---	---	---	---	---	---	---	---	---	---	---	---	---	---

Product coding example:

RB297DEE 2250
1/8" G, auto operation, brass body, EPDM seals, 2.0 mm orifice, 24 VDC, without plug.