

E2014 - Electrically Actuated 2 Way PPGF Flanged Ball Valve

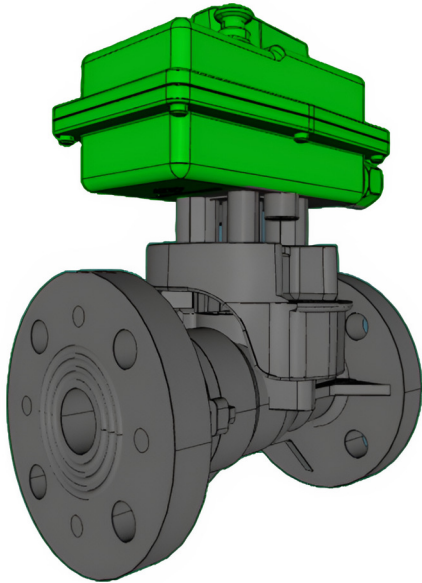

Valve Features and Specification	
Body	PPGF
Seat	PTFE
Seal Options	EPDM Food Grade Acetic EPDM FPM/FKM FEP+FPM+FFPM FEP+FFPM
Flange Options	EN-1092-1/PN16 (DIN) EN1759-1/ASME B16.5 Class 150 (ANSI)
Bore	Full Bore
Operating Temperature:	-10°C to 100°C

Actuator Specification	
Enclosure	Weatherproof IP67 (glass-reinforced polyacrylamide techno-polymer)
Operating Ambient Temperature	-10°C to +50°C
Control Options	2 point or 3 point control
Micro-switches	2x feedback micro switches
Electrical Connection	2 cable gland electrical entries
Power Supply	12v DC, 24v AC/DC, 110v AC, 230v AC
Options:	Fast and slow operating speeds available WIFI configurable SMART actuator Positioning Actuator Fail safe super-capacitor Anti-condensation heater Manual override (AC only)

Pressure / Temperature:

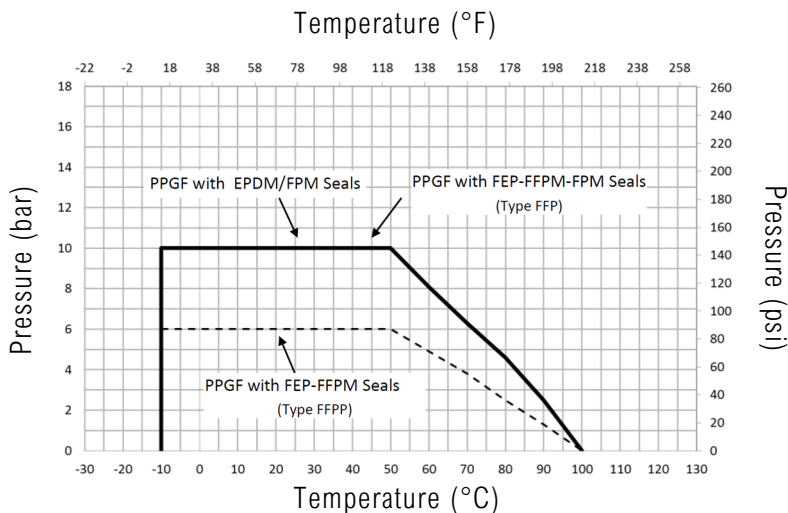

Additional Options Available on-request:

- Flow regulation plate (Material = PVDF)
- Thermal Insulation Extension

Dimensions

E2014 - Electrically Actuated 2 Way PPGF Ball Valve

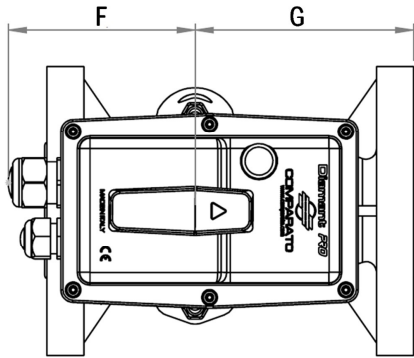
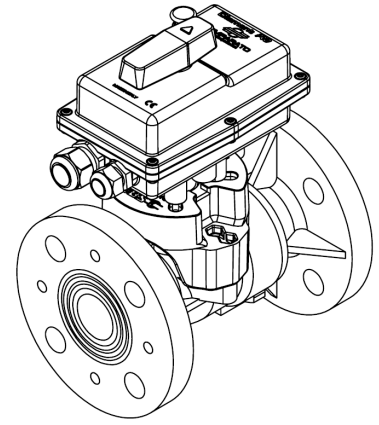
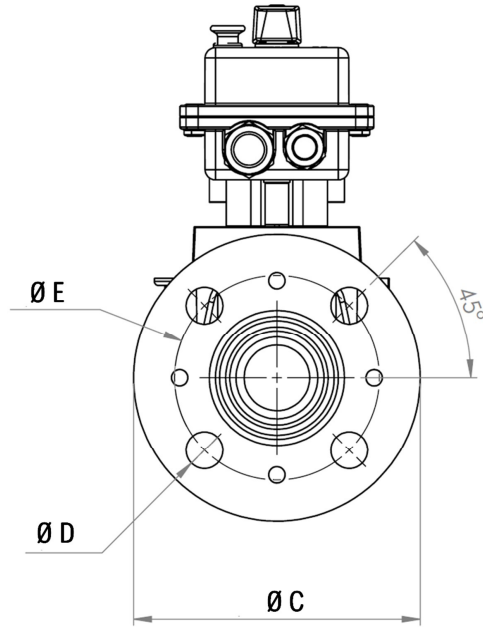
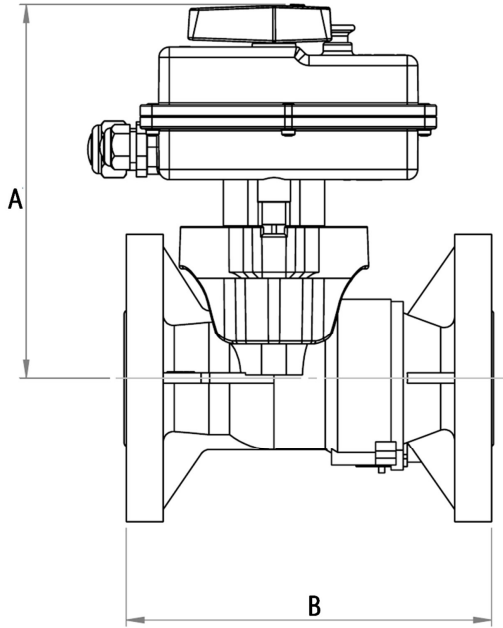

Operating Speeds:

Diamant Pro AC: 35 seconds

Diamant Pro DC: 12 seconds

Compact Pro AC : 45 seconds

Compact Pro DC: 30 seconds

For faster operating speeds please contact us.

Actuator	Diamant Pro					Compact Pro
	15 DN 1/2"	20 3/4"	25 1"	32 1 1/4"	40 1 1/2"	50 2"
A (AC)	170.31	170.31	178.01	182.01	188.81	208.86
A (DC)	188.31	188.31	196.01	200.01	206.81	212.86
B	130	150.1	160	178	200	230
ØC	95.1	105.3	115	140	150	165
ØD	14	14	14	18	16	18
ØE	65	75	85	100	110	125
F	79.2	83.1	90.7	90.7	90.7	99
G	90.7	90.7	90	106	116	131

Dimensions in mm

Actuator Wiring Information:

DC Actuator

2 Point Control - On/Off (Switch)

The voltage on terminal 3 can be supplied by means of a switch.
One electric control can activate several actuators.

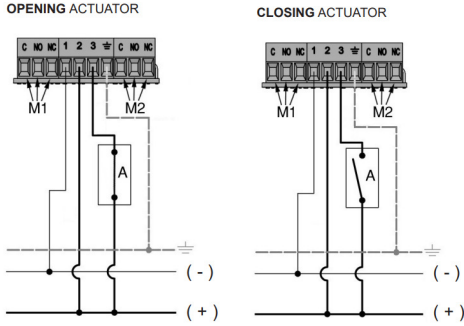

3 Point Control - On/Off (Changeover)

Voltage should be diverted to terminal 2 or 3.
Each actuator must be operated by a single electric control.

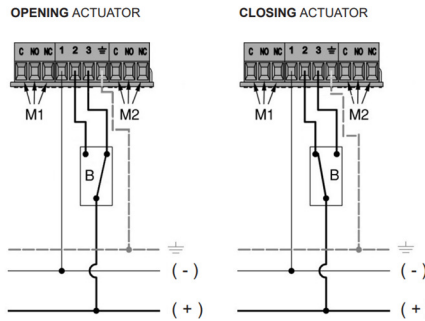

- 1 - Negative (-)
- 2 - Closing control (+)
- 3 - Opening control (+)
- M1 - Opening auxiliary micro
- M2 - Closing auxiliary micro

- B - Deviator-type control
- ⊕ - Earth

If powered by alternating current
(-) = Neutral
(+) = Phase

AC Actuator

2 Point Control - On/Off (Switch)

Terminal 1: neutral;
Terminal 2: fixed closing phase
Terminal 3: opening phase
The phase to terminal 3 can be supplied by means of a switch.
One electric control can activate several actuators.

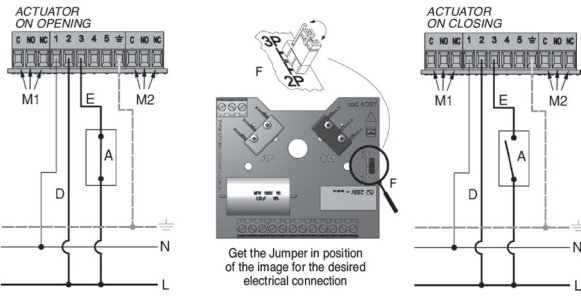

3 Point Control - On/Off (Changeover)

Terminal 1: neutral; Terminal 2: closing phase;
Terminal 3: opening phase
Phase shall be diverted to terminal 2 or terminal 3
Each actuator must be operated by a single electric control

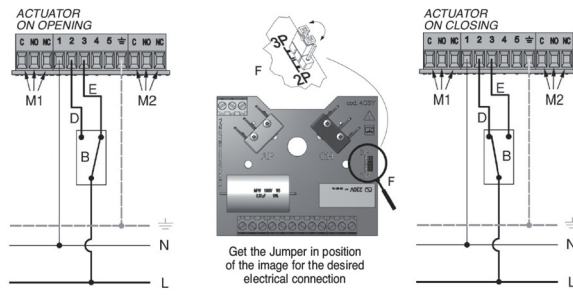

- KEY:
- 1 - Neutral
 - 2 - Closing phase
 - 3 - Opening phase
 - 4 - Outlet opening phase
 - 5 - Outlet closing phase

- B - Switch-type control
- D - Closing
- E - Opening
- F - Jumper
- ⊕ - Earth

- C - Common
- NO - Normally open
- NC - Normally closed
- M1 - Opening extra microswitch
- M2 - Closing extra microswitch

3 Point Control - Modulating (2 Switches)

Terminal 1: neutral;
Terminal 2: fixed closing phase
Terminal 3: opening phase

The phase can be diverted to terminal 2, terminal 3 or to none of them, in order to obtain partial openings of the valve.

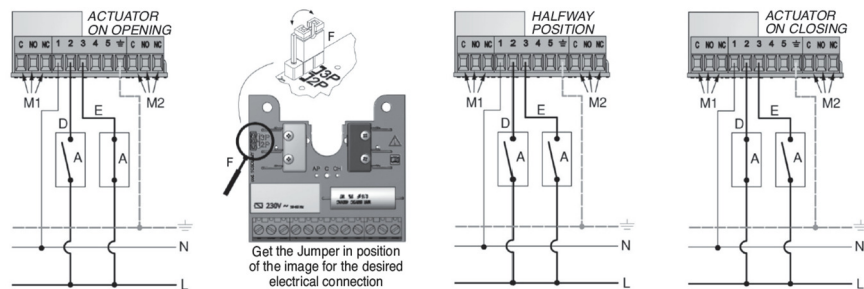

This is necessary for modulating the flow when a regulation is needed. Each actuator must be operated by a single electric control

- KEY:
- 1 - Neutral
 - 2 - Closing phase
 - 3 - Opening phase
 - 4 - Outlet opening phase
 - 5 - Outlet closing phase

- A - Switch-type control
- D - Closing
- E - Opening
- F - Jumper
- ⊕ - Earth

- OPTIONAL
- C - Common
 - NO - Normally open
 - NC - Normally closed
 - M1 - Opening additional microswitch
 - M2 - Closing additional microswitch

Optional Auxiliary Microswitches:

