

# 2/2 Way Piston Actuated Valve G 1/2" to 2", Regular Version – Bronze

Specifications	
Type: CG NC flow over seat 1 → 2	
Type: RCG NO Flow Under Seat 2 → 1	
Type: BCG NC Bi-Directional Flow Over/Under Seat 1 → 2 / 2 → 1	
Type: DCG DA Flow Over/Under Seat 1 ↔ 2	
Media	Water, oil, air, steam <sup>1</sup>
Media Temperature	-10 °C to +180 °C
Ambient Temperature	-10 °C to +60 °C
Pilot Media <sup>2</sup>	Instrument air, inert gases
Actuator Body Material	Polyamide PA6 (reinforced fibreglass 30%)
Body Material	Bronze (CB491K EN1982)
Bonnet Material	Brass (CW617N EN12165)
Seal Material	PTFE
Position Indicator	As standard

## Features and Benefits

- Waterhammer-free design for BCG - DCG (with flow direction 2→1)
- Actuator housing rotation 360°



Options Available
Stroke regulator assembled ex-factory, see page 29 (e.g. code CG205STWR0)
Travel switch assembled ex-factory, see page 29 (e.g. code RCG209STK10)
NPT connection (e.g. code BCN207LTY00)
Design for vacuum applications up to 10 <sup>-2</sup> mbar (e.g. code DCG210STJ0Y)

Accessories
Position module, travel switch kit, pilot solenoid valves see pages 30/31/32

Dimensions & Weights		DN15	DN20	DN25	DN32	DN40	DN50	DN25	DN32	DN40	DN50
Actuator	[mm]	Ø 63						Ø 90			
A	[mm]	65	75	90	110	120	150	90	110	120	150
B	[mm]	192	198	212	225	230	248	223	234	239	257
C	[mm]	184	192	205	217	225	241	216	227	235	250
D	[mm]	171	176	185	193	198	207	196	202	207	216
E	[mm]	85	85	85	85	85	85	112	112	112	112
Weight	[kg]	1.2	1.3	1.5	1.9	2.1	2.9	2.0	2.4	2.6	3.3

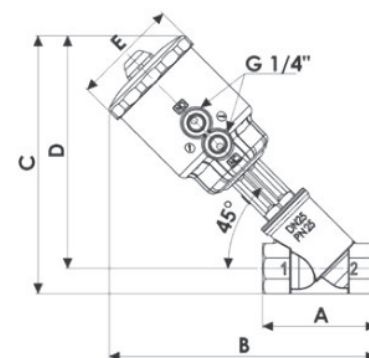

The products listed below comply with the requirements of the European Pressure Equipment Directive 2014/68/UE and carry the CE mark when required. The products fall within the following Pressure Equipment Directive categories:

Valve Type	Bodies	Group 1 gases	Group 1 liquids and Group 2 other fluids
CG - RCG - BCG - DCG	DN15 to DN25 (PN25)	SEP	SEP
	DN32 to DN40 (PN25)	Not suitable	SEP
	DN50 (PN16)	Not suitable	SEP

## ⚠ WARNING!

According to the European Pressure Equipment Directive 2014/68/UE, liquids whose saturated vapour pressure at the maximum allowable temperature is more than 0,5 barg shall be considered as gases.

## 2/2 Way Piston Actuated Valve G 1/2" to 2", Regular Version – Bronze

Valve	Body Connection	DN	Flow Rate Kvs	Working Pressure <sup>1</sup>		Flow Direction	Pilot Pressure <sup>3</sup>		Actuator Ø	Function	
				Min.	Max.		Min.	Max.			
Code	[ISO 228G]	[mm]	[l/min]	[barg]	[barg]	—	[barg]	[barg]	[mm]	—	
CG205STW00	1/2"	15	87	0	20	1 → 2	3.7	10	63	NC	
CG206STX00	3/4"	20	164	0	20	1 → 2	4.4	10			
CG207STY00	1"	25	260	0	20	1 → 2	5	10			
CG208STZ00	1 1/4"	32	410	0	16	1 → 2	5.9	10			
CG209STK00	1 1/2"	40	700	0	16	1 → 2	9	10			
CG210STJ00	2"	50	950	0	11	1 → 2	8	10			
CG207LTY00	1"	25	260	0	20	1 → 2	2	8	90		
CG208LTZ00	1 1/4"	32	410	0	16	1 → 2	3.5	8			
CG209LTK00	1 1/2"	40	700	0	16	1 → 2	4	8			
CG210LTJ00	2"	50	950	0	15	1 → 2	6.5	8			
RCG205STW00	1/2"	15	87	0	16	2 → 1	2.5	10	63		NO
RCG206STX00	3/4"	20	164	0	16	2 → 1	4.3	10			
RCG207STY00	1"	25	260	0	16	2 → 1	5.5	10			
RCG208STZ00	1 1/4"	32	410	0	16	2 → 1	6.5	10			
RCG209STK00	1 1/2"	40	700	0	16	2 → 1	9	10			
RCG210STJ00	2"	50	950	0	12	2 → 1	9.4	10			
RCG207LTY00	1"	25	260	0	16	2 → 1	2	8	90		
RCG208LTZ00	1 1/4"	32	410	0	16	2 → 1	4	8			
RCG209LTK00	1 1/2"	40	700	0	16	2 → 1	5	8			
RCG210LTJ00	2"	50	950	0	16	2 → 1	7	8			
BCG205STW00	1/2"	15	87	0	16	1 → 2 / 2 → 1	5.5 / 3.8	10	63	NC bidirectional	
BCG206STX00	3/4"	20	164	0	16	1 → 2 / 2 → 1	6 / 3.8	10			
BCG207STY00	1"	25	260	0	16 / 11	1 → 2 / 2 → 1	6.5 / 3.8	10			
BCG208STZ00	1 1/4"	32	410	0	16 / 6	1 → 2 / 2 → 1	6.8 / 3.8	10			
BCG209STK00	1 1/2"	40	700	0	12 / 4	1 → 2 / 2 → 1	9 / 3.8	10			
BCG210STJ00	2"	50	950	0	8 / 2.5	1 → 2 / 2 → 1	9 / 3.8	10			
BCG207LTY00	1"	25	260	0	16 / 14	1 → 2 / 2 → 1	4 / 3.3	8	90		
BCG208LTZ00	1 1/4"	32	410	0	16 / 12	1 → 2 / 2 → 1	5 / 3.3	8			
BCG209LTK00	1 1/2"	40	700	0	16 / 8	1 → 2 / 2 → 1	6 / 3.3	8			
BCG210LTJ00	2"	50	950	0	14 / 6	1 → 2 / 2 → 1	8 / 3.3	8			
DCG205STW00	1/2"	15	87	0	16	1 ↔ 2	1.8	2	63		DA
DCG206STX00	3/4"	20	164	0	16	1 ↔ 2	2	3.8			
DCG207STY00	1"	25	260	0	16	1 ↔ 2	3	5			
DCG208STZ00	1 1/4"	32	410	0	16	1 ↔ 2	4.5	6			
DCG209STK00	1 1/2"	40	700	0	16	1 ↔ 2	6.5	7			
DCG210STJ00	2"	50	950	0	12	1 ↔ 2	9	10			

### Notes

1. Steam max. working pressure 10 bar (9 barg)
2. Please contact M&M sales Department for other pilot media
3. Minimum pilot pressure at the max. working pressure: for lower working pressures please refer to the comparative charts