

2/2 Way Piston Actuated Valve G 1/2" to 2", Regular Version - Stainless Steel

Specifications	
Type: PG NC flow over seat 1 → 2	
Type: RPG NO flow under seat 2 → 1	
Type: BPG NC bi-directional flow over/under seat 1 → 2 / 2 → 1	
Type: DPG DA flow over/under seat 1 ↔ 2	
Media	Water, oil, air, aggressive media, steam ¹
Media Temperature	-10 to +180 °C
Ambient Temperature	-10 to +60 °C
Pilot Media ²	Instrument air, inert gases
Body Material	Cast AISI 316L (CF3M), see page 7
Bonnet Material	Cast AISI 316L (CF3M), see page 7
Actuator Body Material	Polyamide + 30% glass fiber
Seal Material	PTFE
Position Indicator	As standard

Options Available
Stroke regulator assembled ex-factory, see page 33 (e.g. code RPG210STJ0)
Travel switch assembled ex-factory, see page 33 (e.g. code PG208STZ0)
NPT connection (e.g. code BPN207LTY00)
High temperature version, see pages 24/25 (e.g. code PG205STW0H)
ATEX version (e.g. code PG205UTW00)

Dimensions & Weights		DN15	DN20	DN25	DN32	DN40	DN50	DN25	DN32	DN40	DN50
Actuator	[mm]	Ø 63						Ø 90			
A	[mm]	65	75	90	110	120	150	90	110	120	150
B	[mm]	188	194	208	221	225	243	218	230	235	254
C	[mm]	180	188	201	213	221	236	211	223	231	246
D	[mm]	168	172	181	189	194	203	191	199	204	213
E	[mm]	79	79	79	79	79	79	115	115	115	115
Weight	[kg]	1.2	1.3	1.5	1.9	2.1	2.9	2.0	2.4	2.6	3.3

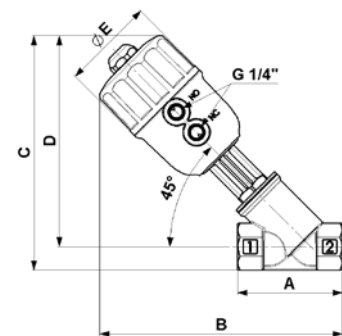

Features and Benefits

- Waterhammer-free design for BPG - DPG (with flow direction 2 → 1)
- Actuator housing rotation 360°
- Design suitable for vacuum applications up to 10⁻² mbar
- ATEX version available

CE ATEX

II 2 G Ex h IIC T6 T4 T5 Gb

II 2 D Ex h IIIC T85°C T100°C T135°C Db



Accessories
Position module, travel switch kit, pilot solenoid valves see pages 34/35/36

The products listed below comply with the requirements of the European Pressure Equipment Directive 2014/68/UE and carry the CE mark when required. The products fall within the following Pressure Equipment Directive categories:

Valve Type	Bodies	Group 1 gases	Group 1 liquids and Group 2 other fluids
PG - RPG - BPG - DPG	DN15 to DN25 (PN40)	art. 4.3	art. 4.3
	DN32 to DN40 (PN25)	Category I	art. 4.3
	DN50 (PN16)	Category I	art. 4.3

⚠ WARNING!

According to the European Pressure Equipment Directive 2014/68/UE, liquids whose saturated vapour pressure at the maximum allowable temperature is more than 0,5 barg shall be considered as gases.

2/2 Way Piston Actuated Valve G 1/2" to 2", Regular Version – Stainless Steel

Valve	Body Connection	DN	Flow Rate Kvs	Working Pressure ¹		Flow Direction	Pilot Pressure ³		Actuator Ø	Function	
Code	[ISO 228G]	[mm]	[l/min]	[barg]	[barg]	—	[barg]	[barg]	[mm]	—	
PG205STW00	1/2"	15	87	0	20	1 → 2	3.9	10	63	NC	
PG206STX00	3/4"	20	164	0	20	1 → 2	4.6	10			
PG207STY00	1"	25	260	0	20	1 → 2	5.2	10			
PG208STZ00	1 1/4"	32	410	0	16	1 → 2	5.7	10			
PG209STK00	1 1/2"	40	700	0	16	1 → 2	8.8	10			
PG210STJ00	2"	50	950	0	11	1 → 2	7.8	10			
PG207LTY00	1"	25	260	0	20	1 → 2	3	8	90		
PG208LTZ00	1 1/4"	32	410	0	16	1 → 2	3	8			
PG209LTK00	1 1/2"	40	700	0	16	1 → 2	4	8			
PG210LTJ00	2"	50	950	0	15	1 → 2	5.8	8			
RPG205STW00	1/2"	15	87	0	16	2 → 1	2.8	10	63		NO
RPG206STX00	3/4"	20	164	0	16	2 → 1	4.5	10			
RPG207STY00	1"	25	260	0	16	2 → 1	5.7	10			
RPG208STZ00	1 1/4"	32	410	0	16	2 → 1	6.7	10			
RPG209STK00	1 1/2"	40	700	0	14	2 → 1	9.2	10			
RPG210STJ00	2"	50	950	0	12	2 → 1	9.6	10			
RPG207LTY00	1"	25	260	0	16	2 → 1	4.5	7	90		
RPG208LTZ00	1 1/4"	32	410	0	16	2 → 1	4	7			
RPG209LTK00	1 1/2"	40	700	0	16	2 → 1	5.4	7			
RPG210LTJ00	2"	50	950	0	16	2 → 1	7	7			
BPG205STW00	1/2"	15	87	0	16	1 → 2 / 2 → 1	5.9 / 4.2	10	63	NC bidirectional	
BPG206STX00	3/4"	20	164	0	16	1 → 2 / 2 → 1	6.4 / 4.2	10			
BPG207STY00	1"	25	260	0	16 / 11	1 → 2 / 2 → 1	6.9 / 4.2	10			
BPG208STZ00	1 1/4"	32	410	0	16 / 6	1 → 2 / 2 → 1	7 / 4.2	10			
BPG209STK00	1 1/2"	40	700	0	12 / 4	1 → 2 / 2 → 1	9.4 / 4.2	10			
BPG210STJ00	2"	50	950	0	8 / 2.5	1 → 2 / 2 → 1	9.4 / 4.2	10			
BPG207LTY00	1"	25	260	0	16 / 14	1 → 2 / 2 → 1	4 / 3.8	8	90		
BPG208LTZ00	1 1/4"	32	410	0	16 / 12	1 → 2 / 2 → 1	5 / 3.8	8			
BPG209LTK00	1 1/2"	40	700	0	16 / 8	1 → 2 / 2 → 1	6.5 / 3.8	8			
BPG210LTJ00	2"	50	950	0	14 / 6	1 → 2 / 2 → 1	7 / 3.8	8			
DPG205STW00	1/2"	15	87	0	16	2 → 1	1.8	2	63		DA
DPG206STX00	3/4"	20	164	0	16	2 → 1	2	3.8			
DPG207STY00	1"	25	260	0	16	2 → 1	3	5			
DPG208STZ00	1 1/4"	32	410	0	16	2 → 1	4.5	6			
DPG209STK00	1 1/2"	40	700	0	16	2 → 1	6.5	7			
DPG210STJ00	2"	50	950	0	12	2 → 1	8	10			

Notes

1. Steam max. working pressure 10 bar (9 barg)
2. Please contact M&M sales Department for other pilot media
3. Minimum pilot pressure at the max. working pressure: for lower working pressures please refer to the comparative charts
4. Pav ATEX performances are the same as weather proof pav